

MIPI-OPT06

User Manual

Ver. 1.1

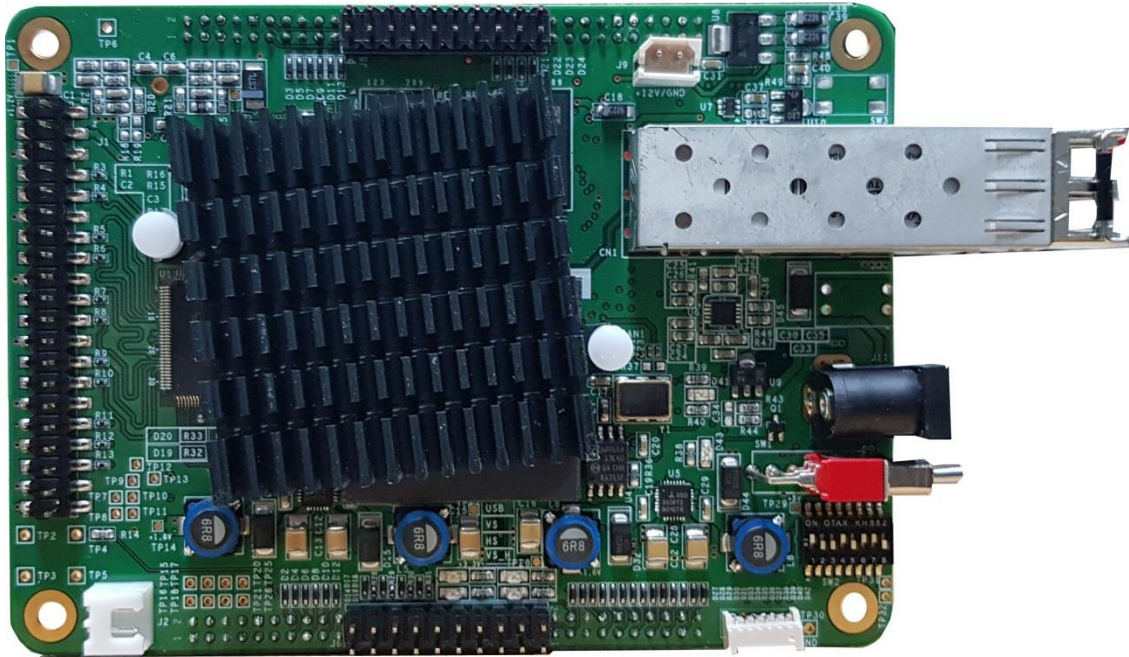

© 2005 DAQ SYSTEM Co., Ltd. All rights reserved.

Microsoft® is a registered trademark; Windows®, Windows NT®, Windows XP®, Windows 7®, Windows 8®, Windows 10®
All other trademarks or intellectual property mentioned herein belongs to their respective owners.

Information furnished by DAQ SYSTEM is believed to be accurate and reliable, However, no responsibility is assumed by DAQ SYSTEM for its use, nor for any infringements of patents or other rights of third parties which may result from its use. No license is granted by implication or otherwise under any patent or copyrights of DAQ SYSTEM.

The information in this document is subject to change without notice and no part of this document may be copied or reproduced without the prior written consent.

Contents

1. Summary

1-1. Product Specification	-----	2
1-2. Application Filed	-----	3

2. MIPI-OPT06 Board Description

2-1. Board Layout	-----	4
2-2. Board Description	-----	5
2-3. I/O Terminal Pin Map	-----	6
(1) CN1 Connector	-----	6
(2) J1 Connector	-----	6
(3) J3 Connector	-----	8
(4) J4 Connector	-----	9
(5) J5 Connector	-----	10
(6) J6 Connector	-----	11
(7) J7 Connector	-----	12
(8) J8 Connector	-----	13
(9) J11 Power Connector	-----	14
(10) SW1 Switch	-----	14
(11) SW2 Switch	-----	15

3. Sample Program

3-1. Board Function	-----	17
3-2. Image Function	-----	18
3-3. Clock Function	-----	21
3-4. Power/Digital/IO Function	-----	22
3-5. I2C Function	-----	23
3-6. Auto Test Function	-----	24
3-7. SPI Function	-----	24
3-8. OS SPI Function	-----	25
3-9. MISC Function	-----	25
3-10. STATUS Function	-----	26

Appendix

A-1. Board Size	-----	27
A-2. Repair Regulations	-----	28

1. Summary

1-1. Product Specification

Item	Description	Remark
Hardware		
PC Interface	Fiber-Transmission Transceiver	SFP(small Form Factor)
Operation Power	+12VDC/400mA	External 12V DC Power (A6-Type : 5.5x2.1mm)
Video Interface	MIPI CSI C-PHY 3 Lane MIPI CSI D-PHY 4 Lane	2.2 ~ 2.3 Gsym / 1 Lane 2.5Gbps / 1 Lane
Input/Output No.	Sensor GPIO 4bit General GPIO 12bit User GPIO 12bit	3.3V GPIO 4bit, User GPIO 8bit
On-board Memory	2Gb (DDR3) x2	
Communication	I2C/SPI	
Number of boards used simultaneously	Max. 4	
Software		
OS	Windows 2000/XP/7/8/10 (32/64bit)	Use with PCIe-OPT01
API		
Development		
Support		
Environmental conditions		
Operating temperature range	0 ~ 50°C (0 ~ 60°C when using fan)	
Storage temperature range	-20 ~ 80°C	
Humidity range	Non-condensing	
Board size	110mm x 80mm 140mm x 80mm	PCB Board Size Size including Case/SFP

1-2. Application Field

- Frame Grabber
- Test for Variable MIPI Sensor

The MIPI-OPT06 board transmits the C-PHY or D-PHY MIPI (Mobile Industry Processor Interface) signal of the sensor board to the PC in an optical method. Two signals of C-PHY or D-PHY can be selected and used. The received signal is processed by the software (application) provided by the DAC system in the PC and displayed as an image.

[Figure 1-1] shows an example of using the input board.

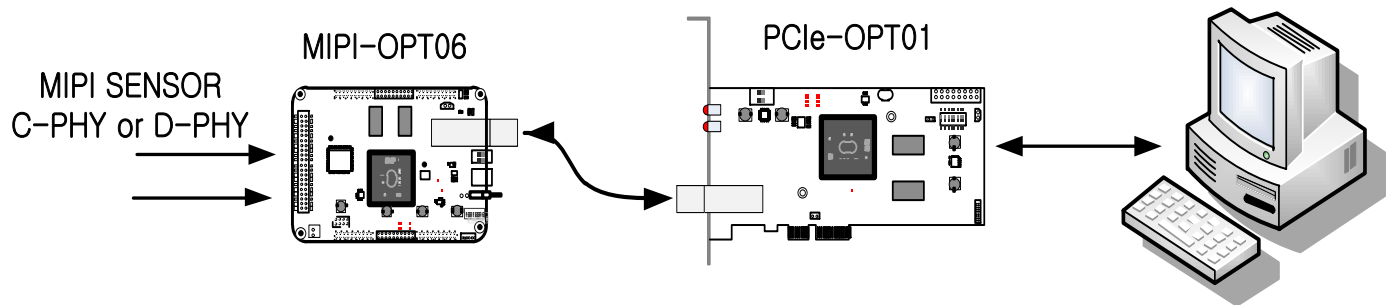

[Figure 1-1. MIPI-OPT06 Example of Use]

2. MIPI-OPT06 Board Description

2-1. Board Layout

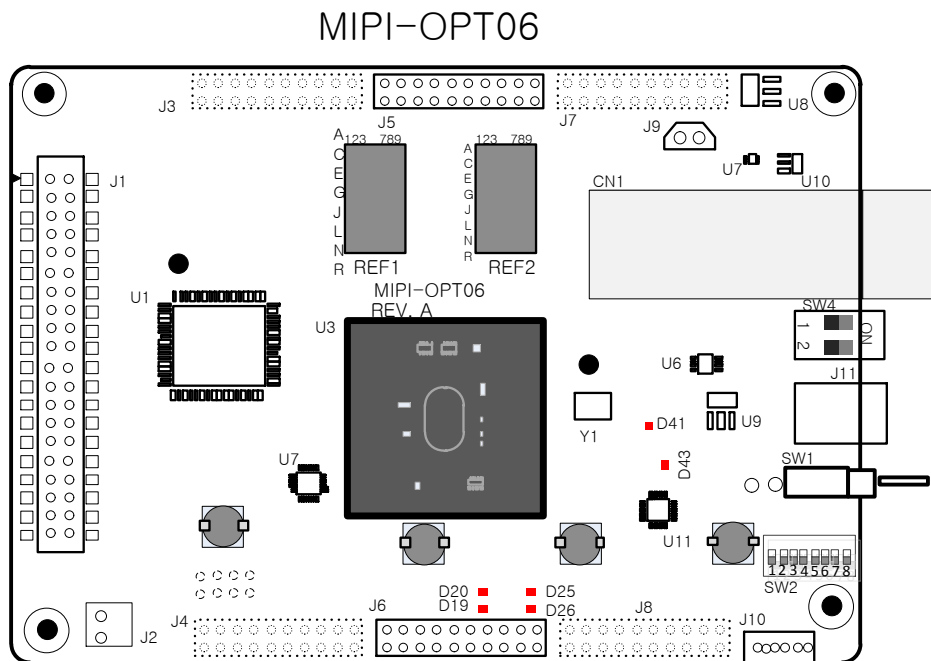

[Figure 2-1. MIPI-OPT06 Layout]

No.	Name	Description/Remark
1	CN1	SFP (8Gbps)
2	U8, U9	1.2V, 2.5V, 3.3V
3	U1	MIPI C-PHY/D-PHY Combo Chip
4	U3	FPGA
5	REF1/REF2	Image Buffer (DDR3 256MB)
6	J1	MIPI Board Connection Connector (For MIPI Signals)
7	J3~ J8	General Purpose IO or PWR/OS/AD Communication
8	J11	Power Adaptor (12V)
9	SW1	Power Switch

There are 6 important LEDs on the board, and the description of each is as follows.

D20: Lights up after completion of initialization.

D19: Vertical Synchronization signal line (Vsync) is connected.

This is a mark for visually checking Vsync.

D25: Horizontal Synchronization signal line (Hsync) is connected.

This is a mark to visually check Hsync.

D26: Displays the vertical synchronization (Vsync) divided by 1/16.

This is a mark for visually checking Vsync.

D41: Lights when the board is configured and ready for operation.

D43: Lights when 3.3V power is applied.

2-2. Board Description

The MIPI-OPT06 board converts MIPI D-PHY or C-PHY signals received from MIPI sensors and transmits light. All functions are controlled by the FPGA.

The block diagram of MIPI-OPT06 is as shown in [Figure 2-2].

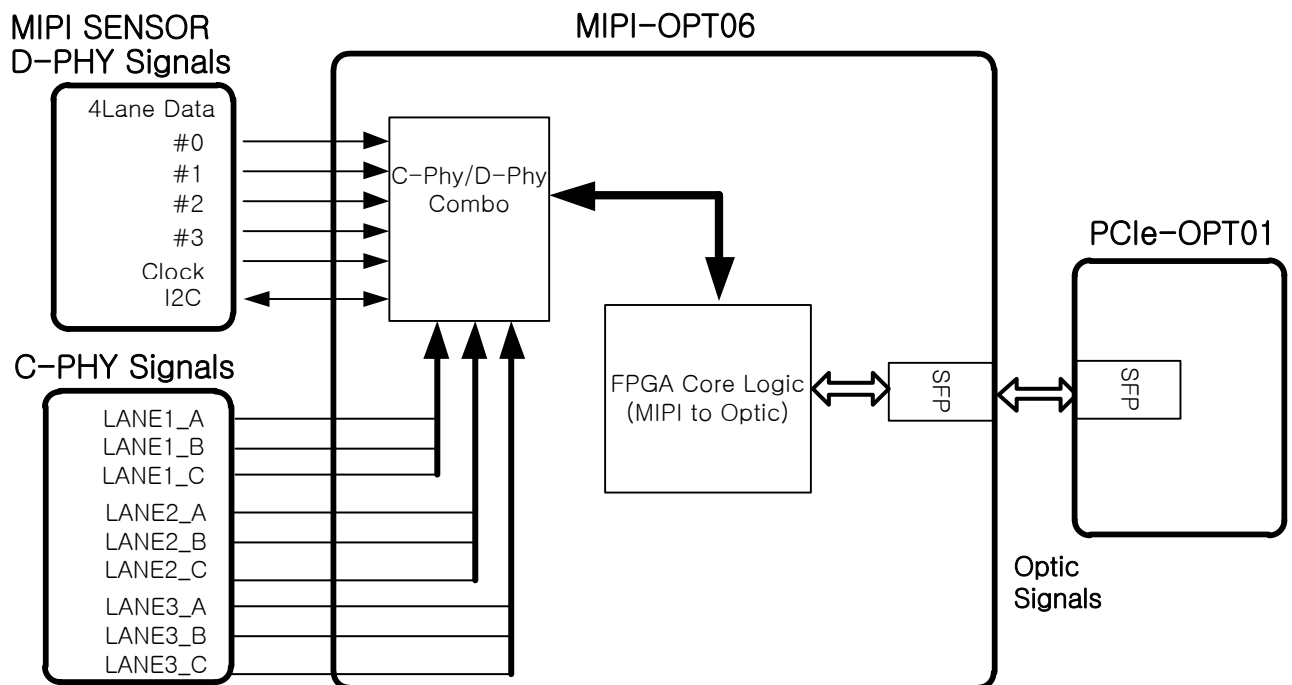

[Figure 2-2. MIPI-OPT06 Block Diagram]

The program of the FPGA core logic uses JTAG, and functions to save the logic program in the FPGA Program Logic and download it when power is applied..

2-3. I/O Terminal Pin map

(1) CN1 Connector

In the case of MIPI-OPT06, a Small Form Factor Pluggable (SFP) connector is used as a Fiber-Transmission Transceiver. The SFP transceiver is designed to support various optical transmissions such as SONET, Gigabit Ethernet, and Fiber Channel. It supports hot-pluggable transceiver and can be connected to network device motherboard with fiber or copper networking cable.

The SFP is connected by a module that connects to the cage and connector, and has Tx (Transceiver) and Rx (Receiver) together.



[Figure 2-3. SFP & SFP Cage]

(2) J1 Connector (2x20 Pin Straight Male SMD Type)

It is connected to the MIPI SENSOR board and the signals are as follows.

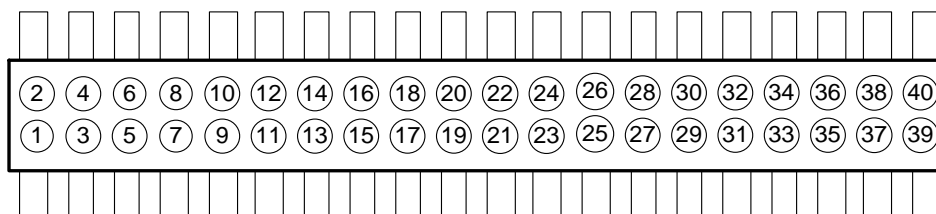

[Figure 2-4. J1 Connector (Top View)]

[Table 1. J1 Connector Description]

No.	Name	Description	Remark
1	SP0	SENSOR Power	

2	SP1	SENSOR Power	
3	SP2	SENSOR Power	
4	SP3	SENSOR Power	
5	GND	Ground	
6	GND	Ground	
7	SCL	Serial Clock	
8	C_L0_RXA or D_L0_RXP	C_lane0_RX_A or D_lane0_RX_P	C : C-Phy, D : D-Phy
9	SDA	Serial Data	
10	C_L0_RXB or D_L0_RXN	C_lane0_RX_B or D_lane0_RX_N	C : C-Phy, D : D-Phy
11	GND	Ground	
12	GND	Ground	
13	ENB	Enable	
14	C_L0_RXC or D_L1_RXP	C_lane0_RX_C or D_lane1_RX_P	C : C-Phy, D : D-Phy
15	S_RESET	Reset	
16	C_L1_RXD or D_L1_RXN	C_lane1_RX_D or D_lane1_RX_N	C : C-Phy, D : D-Phy
17	GND	Ground	
18	GND	Ground	
19	S_GPIO0	Sensor GPIO0	Using the PCI_SDIO_xxx function
20	C_L2_RXA or D_L2_RXP	C_lane2_RX_A or D_lane2_RX_P	C : C-Phy, D : D-Phy
21	S_GPIO1	Sensor GPIO1	Using the PCI_SDIO_xxx function
22	C_L2_RXB or D_L2_RXN	C_lane2_RX_B or D_lane2_RX_N	C : C-Phy, D : D-Phy
23	GND	Ground	
24	GND	Ground	
25	S_GPIO2	Sensor GPIO2	Using the PCI_SDIO_xxx function
26	C_L2_RXC or D_L3_RXP	C_lane2_RX_C or D_lane3_RX_P	C : C-Phy, D : D-Phy
27	S_GPIO3	Sensor GPIO3	Using the PCI_SDIO_xxx function
28	C_L2_RXD or D_L3_RXN	C_lane2_RX_D or D_lane3_RX_N	C : C-Phy, D : D-Phy
29	GND	Ground	
30	GND	Ground	
31	GND	Ground	
32	C_L1_RXA or D_CLK_RXP	C_lane1_RX_A or D_CLK_RX_P	C : C-Phy, D : D-Phy
33	GND	Ground	
34	C_L1_RXB or D_CLK_RXN	C_lane1_RX_B or D_CLK_RX_N	C : C-Phy, D : D-Phy
35	MCLK	Master Clock	
36	C_L1_RXC	C_lane2_RX_C	C : C-Phy,
37	GND	Ground	
38	GND	Ground	

39	SP4	SENSOR Power	
40	SP5	SENSOR Power	

(3) J3 Connector

It is connected to the MIPI power board and is a connector related to sensor power and some communication.

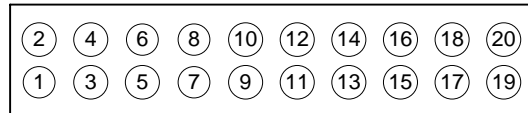

[Figure 2-5. J3 Connector (Top View)]

[Table 2. J3 Connector Description]

No.	Name	Description	Remark
1	GND	Ground	
2	GND	Ground	
3	SP0	SENSOR Power	0.9 ~ 4.1V
4	SP1	SENSOR Power	0.9 ~ 4.1V
5	SP2	SENSOR Power	0.9 ~ 4.1V
6	SP3	SENSOR Power	0.9 ~ 4.1V
7	GND	Ground	
8	GND	Ground	
9	SCL	Serial Clock	3.3V
10	SDA	Serial Data	3.3V
11	PWR_SCL	Power Serial Clock	3.3V
12	PWR_SDA	Power Serial Data	3.3V
13	AD_SCL	AD Converter Serial Clock	3.3V
14	AD_SDA	AD Converter Serial Data	3.3V
15	GND	Ground	
16	GND	Ground	
17	OS_SCL	Open/Short Serial Clock	3.3V
18	OS_SDA	Open/Short Serial Data	3.3V
19	GND	Ground	
20	GND	Ground	

(4) J4 Connector

It is connected to the MIPI power board, and is a connector related to sensor power, SPI communication, and some GPIO (General Purpose In/Out).

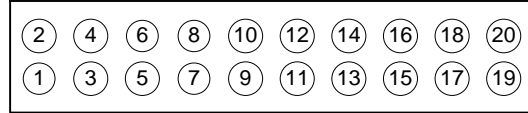

[Figure 2-6. J4 Connector (Top View)]

[Table 3. J4 Connector Description]

No.	Name	Description	Remark
1	GND	Ground	
2	GND	Ground	
3	SP4	User Defined Power	0.9 ~ 4.1V
4	SP5	User Defined Power	0.9 ~ 4.1V
5	GND	Ground	
6	GND	Ground	
7	SPI_SCK	Serial Clock	3.3V
8	SPI_MOSI	Master Output, Slave Input	3.3V
9	SPI_EN	Slave Select	3.3V
10	SPI_MISO	Master Input, Slave Output	3.3V
11	5V_IN	5V Power	
12	V_IO2	IO2 Power	
13	GPIO0	General Purpose IO0	Using the PCI_PWR_DIO_xxx function
14	GPIO1	General Purpose IO1	Using the PCI_PWR_DIO_xxx function
15	GPIO2	General Purpose IO2	Using the PCI_PWR_DIO_xxx function
16	GPIO3	General Purpose IO3	Using the PCI_PWR_DIO_xxx function
17	GPIO4	General Purpose IO4	Using the PCI_PWR_DIO_xxx function
18	GPIO5	General Purpose IO5	Using the PCI_PWR_DIO_xxx function
19	GND	Ground	
20	GND	Ground	

(5) J5 Connector

It is a connector used for Power/AD Convertor/OpenShort communication line and some GPIOs.

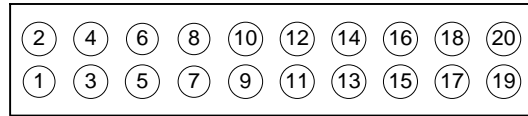

[Figure 2-7. J5 Connector (Top View)]

[Table 4. J5 Connector Description]

No.	Name	Description	Remark
1	GND	Ground	
2	GND	Ground	
3	SCL	Serial Clock	3.3V
4	SDA	Serial Data	3.3V
5	PWR_SCL_FU	Power Serial Clock	3.3V
6	PWR_SDA_FU	Power Serial Data	3.3V
7	AD_SCL_FU	AD Converter Serial Clock	3.3V
8	AD_SDA_FU	AD Converter Serial Data	3.3V
9	OS_SCL_FU	Open/Short Serial Clock	3.3V
10	OS_SDA_FU	Open/Short Serial Data	3.3V
11	GND	Ground	
12	GND	Ground	
13	VCC12_WALL	12V Adaptor Power	12V
14	VCC12_WALL	12V Adaptor Power	12V
15	GPIO8	General Purpose IO8	1.5 ~ 3.3V
16	GPIO9	General Purpose IO9	1.5 ~ 3.3V
17	GPIO10	General Purpose IO10	1.5 ~ 3.3V
18	GPIO11	General Purpose IO11	1.5 ~ 3.3V
19	GND	Ground	
20	GND	Ground	

(6) J6 Connector

This connector is used for SPI (Serial Peripheral Interface) and some GPIOs.

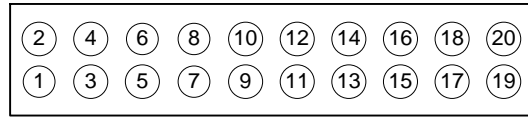

[Figure 2-8. J6 Connector (Top View)]

[Table 5. J6 Connector Description]

No.	Name	Description	Remark
1	GND	Ground	
2	GND	Ground	
3	SPI_CLK_CON	Serial Clock	3.3V
4	SPI_MOSI_CON	Master Output, Slave Input	3.3V
5	SPI_EN_CON	Slave Select	3.3V
6	SPI_MISO_CON	Master Input, Slave Output	3.3V
7	GND	Ground	
8	5V_IN	5V Power	5V
9	V_IO2	IO2 Power	V_IO2 Power
10	GND	Ground	
11	GPIO0	General Purpose IO0	1.5 ~ 3.3V
12	GPIO1	General Purpose IO1	1.5 ~ 3.3V
13	GPIO2	General Purpose IO2	1.5 ~ 3.3V
14	GPIO3	General Purpose IO3	1.5 ~ 3.3V
15	GPIO4	General Purpose IO4	1.5 ~ 3.3V
16	GPIO5	General Purpose IO5	1.5 ~ 3.3V
17	GPIO6	General Purpose IO6	1.5 ~ 3.3V
18	GPIO7	General Purpose IO7	1.5 ~ 3.3V
19	GND	Ground	
20	GND	Ground	

(7) J7 Connector

This connector is connected to the MIPI power board.

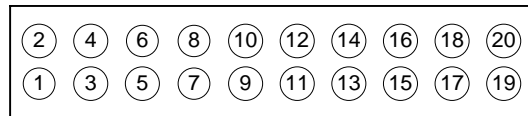

[Figure 2-9. J7 Connector (Top View)]

[Table 6. J7 Connector Description]

No.	Name	Description	Remark
1	GND	Ground	
2	GND	Ground	
3	GPIO8	General Purpose IO8	Using the PCI_PWR_DIO_xxx function
4	GPIO9	General Purpose IO9	Using the PCI_PWR_DIO_xxx function
5	GPIO10	General Purpose IO10	Using the PCI_PWR_DIO_xxx function
6	GPIO11	General Purpose IO11	Using the PCI_PWR_DIO_xxx function
7	GND	Ground	
8	GND	Ground	
9	5V_IN	5V Power	5V
10	5V_IN	5V Power	5V
11	5V_IN	5V Power	5V
12	5V_IN	5V Power	5V
13	GND	Ground	
14	GND	Ground	
15	VCC12_WALL	12V Adaptor Power	12V
16	VCC12_WALL	12V Adaptor Power	12V
17	VCC12_WALL	12V Adaptor Power	12V
18	VCC12_WALL	12V Adaptor Power	12V
19	GND	Ground	
20	GND	Ground	

(8) J8 Connector

It is connected to the MIPI power board and is a connector related to GPIO (General Purpose In/Out).

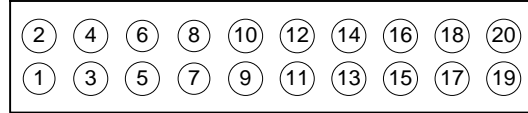

[Figure 2-10. J8 Connector (Top View)]

[Table 7. J8 Connector Description]

No.	Name	Description	Remark
1	GND	Ground	
2	GND	Ground	
3	GPIO6	General Purpose IO6	Using the PCI_PWR_DIO_xxx function
4	GPIO7	General Purpose IO7	Using the PCI_PWR_DIO_xxx function
5	GND	Ground	
6	GND	Ground	
7	U3_GPIO0	User General Purpose IO0	Using the PCI_DIO33_xxx function
8	U3_GPIO1	User General Purpose IO1	Using the PCI_DIO33_xxx function
9	U3_GPIO2	User General Purpose IO2	Using the PCI_DIO33_xxx function
10	U3_GPIO3	User General Purpose IO3	Using the PCI_DIO33_xxx function
11	U_GPIO0	User General Purpose IO0	Using the PCI_DIO_xxx function
12	U_GPIO1	User General Purpose IO1	Using the PCI_DIO_xxx function
13	U_GPIO2	User General Purpose IO2	Using the PCI_DIO_xxx function
14	U_GPIO3	User General Purpose IO3	Using the PCI_DIO_xxx function
15	U_GPIO4	User General Purpose IO4	Using the PCI_DIO_xxx function
16	U_GPIO5	User General Purpose IO5	Using the PCI_DIO_xxx function
17	U_GPIO6	User General Purpose IO6	Using the PCI_DIO_xxx function
18	U_GPIO7	User General Purpose IO7	Using the PCI_DIO_xxx function
19	GND	Ground	
20	GND	Ground	

(9) J11 Power Connector

It is an external 12V DC Jack (A6 Type: 5.5x2.1mm) power connector of DC-005(2.0) standard.

(Recommended for basic use)



[Figure 2-11. Rated power]

(10) SW1 Switch

When the terminal is raised with the board power On/Off switch, the 12V power is turned on.

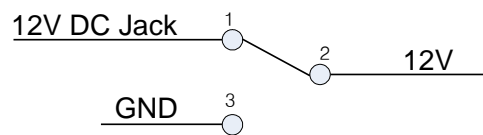

[Figure 2-12. SW1 Switch]

(11) SW2 Switch

It is set at the factory as an optional function. (Customer use is prohibited)

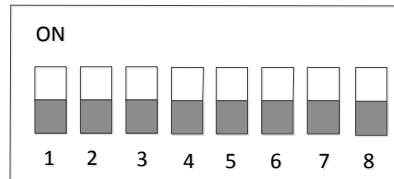

[Figure 2-13. SW2 Switch (Top View)]

[Table 8. SW2 PIN-OUT Description]

No.	Description
1	BIAS0
2	BIAS1
3	BIAS2
4	BIAS3
5	BIAS4
6	BIAS5
7	BIAS6
8	BIAS7

3. Sample Program

In the Exe folder of the CDROM provided with the board, a sample program "FrameTest.exe" is provided for easy use of the board. This program runs on a PC equipped with a PCIe-OPT01 board. By displaying Frame Data as a hexadecimal value, it is stored in memory or hard disk so that developers can utilize the frame data needed. In order to test the sample program, the driver of the board must be installed first.

The sample program is provided in the form of a source so that the API provided to use the board can be tested briefly, so the user can modify it and use it.

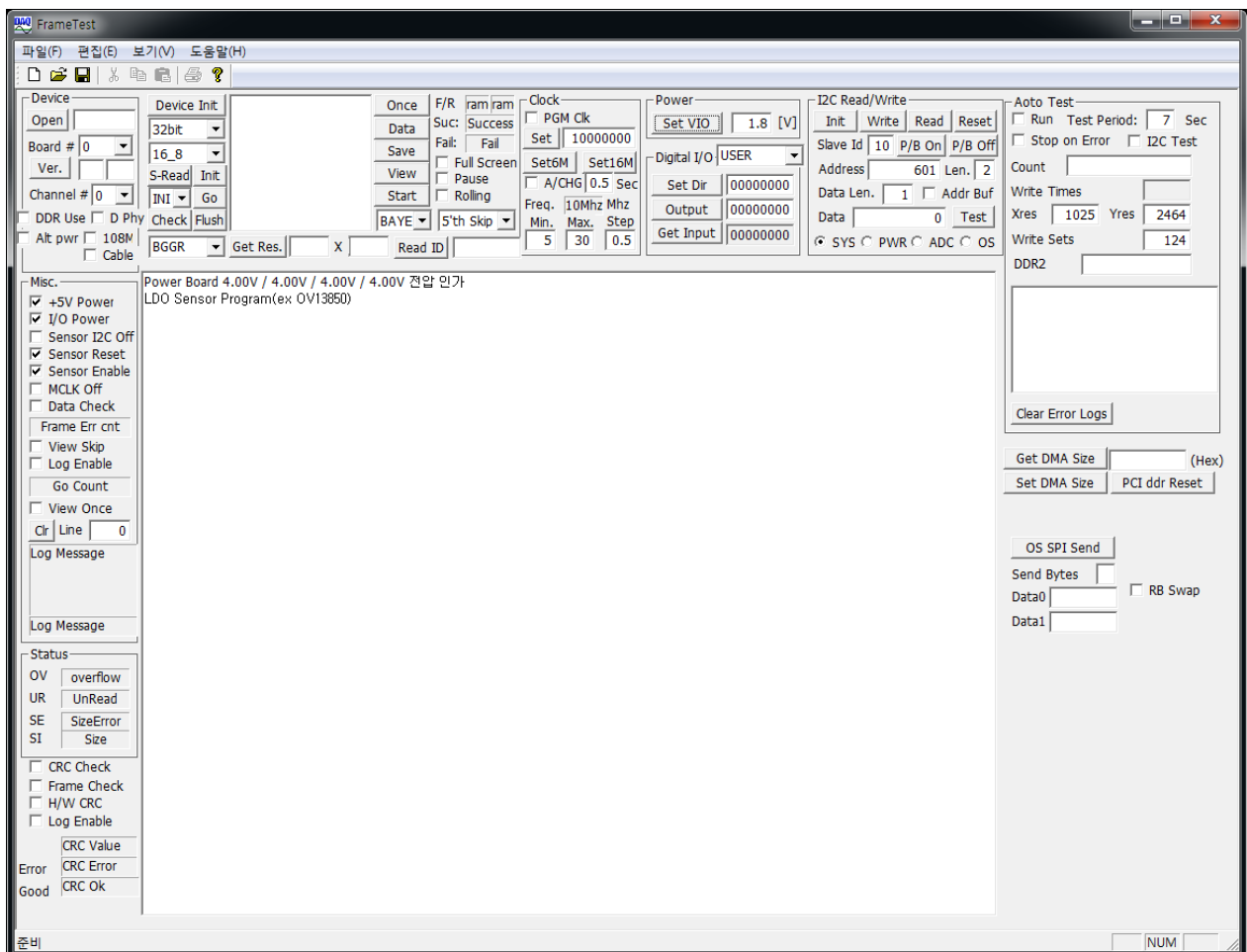

[Figure 3-1. Sample Program "FrmTest.exe"]

API (Application Programming Interface) is required to use the above sample program. API is provided in the form of "DLL", and import library and header file are required to compile. All files specified above are included on the supplied CDROM. In order to run the sample program normally, it must be in the API DLL (mipi_iot.dll) or in the Windows system folder or the folder specified by the Path environment variable.

The description of each menu bar is as follows. The menu bar not described here is an unused function.

(Note) The sample program execution sequence is to select Board # and Channel # first, then click "Open" → Select the format suitable for the camera in "Data mode" → Select the camera data width Select from among "8, 16, 24, 32bit" → "Device Init" → Select the sensor *.ini file in S-Read (*.ini file address and data selection, in case of D-Phy, select D Phy) → Go (Check "Get Res." resolution) → Image is real-time show

3.1 Board Function

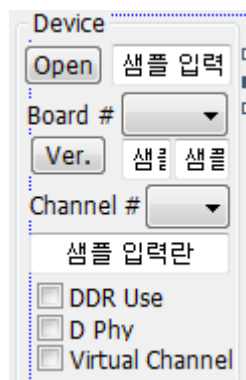

(1) "Device Open" button

Starts the device of the selected board. If it is "0", it means that there is no device or no connection.

(2) "Board # :"

If the board is multi, the board number is assigned.
Currently, 4 can be selected from 0 to 3. Each board number is identified by a switch (J10) in the board..

(3) " Ver." button

Shows the current FPGA version and firmware version.

(4) "Channel # :"

Specifies the fiber channel number. If it is "0", it is connected to the lower optical channel (CN2), and if it is "1", it is connected to the upper optical channel (CN1).

- (5) **"Sample Input"** : Among MIPI-OPT06 or MIPI-OPT08, the name of the board connected to PCIe-OPT01 appears.

DDR Use : It uses DDR memory.

D Phy : When selected, set D-Phy as the LVDS input mode. The default setting is C-PHY.

Virtual Channel : MIPI Virtual Channel is used when selected.

3.2 Image Frame Function

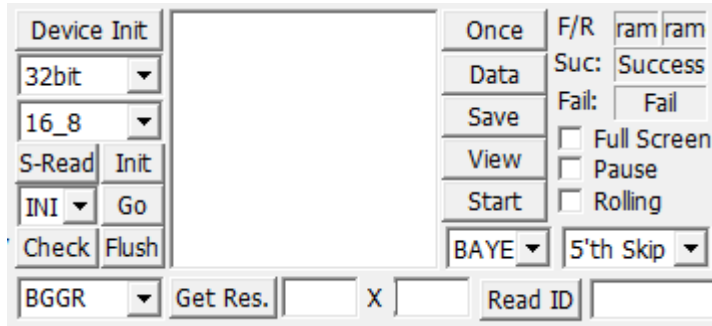

(1) "Device Init" button

Initialize the image frame function. It is performed only once when the first power is applied. Select Video Data Mode from among 8bit, 16bit, 24bit, and 32bit.

(2) "S-Read" button

Read the sensor initialization file. Depending on the address_data size (16_8, 16_16) above, it is possible to send commands to the INI file at once, or use I2C read/write commands line by line. The structure and description of the ini file are as follows. The following example is a 1 byte structure of address_data size of 16_8 address 2 bytes data.

Ex) SONY13M_full.ini file structure

```
[REGISTER]
Slave  0x10 //change slave ID as Sensor

SLEEP  100
0x3087 0x53
0x309D 0x94
0x30A1 0x08
0x30AA 0x04
0x30B1 0x00
0x30C7 0x00
0x3115 0x0E
0x3118 0x42
0x311D 0x34
0x3121 0x0D
```

```

0x3212 0xF2
0x3213 0x0F

.....

0x3306 0x12
0x3307 0x03
0x3308 0x0D
0x3309 0x05
0x330A 0x09
0x330B 0x04
0x330C 0x08
0x330D 0x05
0x330E 0x03
0x3318 0x65
0x3348 0xE0
0x0100 0x01 //Streaming

```

(3) "Init" button

Initialize the sensor by selecting "SNI, T1, T2, SPI".

(4) "Go" button

Open the device, initialize it, open the corresponding ini file and get the resolution all at once

(5) "Check" button

Check the USB connection. In case of an error, "LVDS Check Error" is displayed.

(6) "Flush" button

Initialize the LVDS buffer.

(7) "RGGB;BGGR;GRBG;BGGR" : Choose from Bayer Mode**(8) "Get Res." button**

Shows the image resolution.

(9) "Once" button

Press the Toggle button to display the screen once.

(10) "Data" button

It reads the image frame saved on the board to the PC (Hexa value). If the image frame is not saved on the board, you have to wait until the saving is completed.

(11) "Save" button

It is used to save the frame image data read into the PC as a binary file file.

(12) "View" button

Start sending images.

(13) "Start" button

Start image transfer with "Start" and "stop" Toggle buttons.

(14) "BAYER;RGB;YUV;USER" : Select custom or image input format type

"No Skip; There is no byte skip.

"5'th Skip" : When input data is 10bit RAW data, skip the 5th byte on selection.

For example, if the input data is a 10-bit Bayer, 8 bits are stored in the 5th byte, each of which is 1 bit excluding 3 bytes of RGB and 1 byte. When the Bayer is processed and displayed on the screen, the 5th byte is not needed, so it is used to remove it.

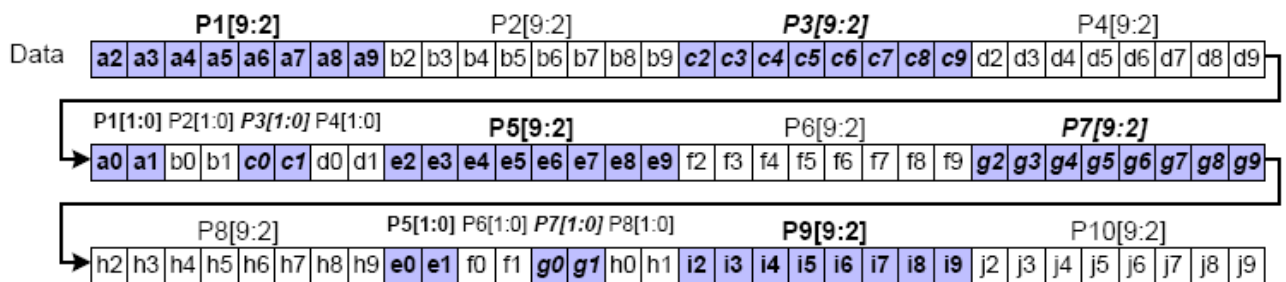

"3'th Skip" : When input data is 12bit RAW data, skip the 3th byte on selection.

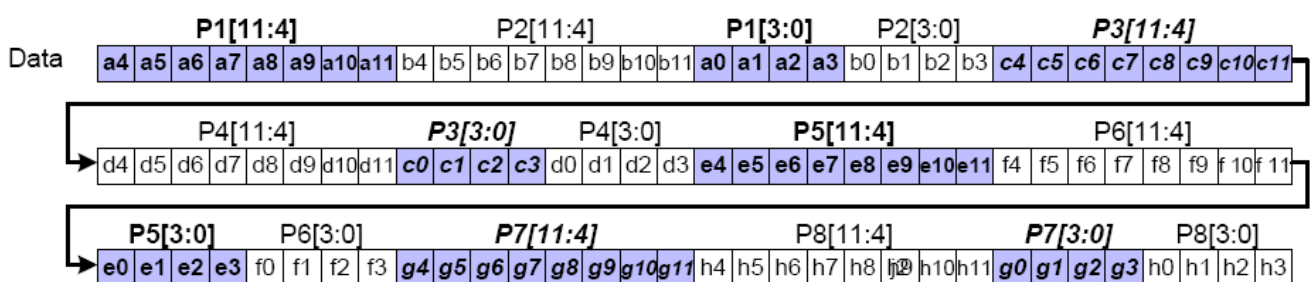

(15) "F/R : " : (Right) Shows the number of frames displayed on the screen.

(Left) Shows the actual number of frames sent from the sensor.

"Suc: " : Shows the number of successful image transfers.

"Fail: " : Shows the number of failed image transfers.

"Full Scr." : Displays the screen in real resolution.

"Pause" : Pause the screen.

"Rolling" : Update image data without using GetFrame function.

(16) **"Read ID" button**

Shows MIPI ID.

3.3 Clock Function

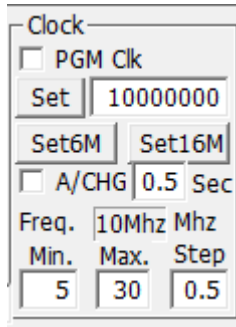
(1) **"PGM Clk" toggle**

Select the corresponding Sensor Clock.

(2) **"Set" button**

It is set according to the frequency set next to the Sensor Clock. In the above case, it is set to 10MHz.

(3) **"Set 6M" button**

Set the Sensor Clock to 6MHz.

(4) **"Set 16M" button**

Set the Sensor Clock to 16MHz..

(5) **"A/CHG" toggle**

If you check, the Min. Max. It can be tested by periodically setting the interval of the frequency determined by Step.

Ex) In the above case, the frequency increases in units of 0.5MHz between 5 and 30Mz, and the period increases in units of $0.5 \times 1000\text{ms} = 500\text{ms}$ as the number next to A/CHG.

3.4 Power/Digital/IO Function

(1) **“Set VIO” button**

User GPIO7..0 IO voltage value (default 1.8V) can be specified and set. (0 ~ 3.3V)

(2) **Digital I/O (USER;Sensor;User3.3V;PWR) : Selection**

(Based on Power Board connection)

PCI_DIO_XXXX : User GPIO7..0 General Purpose I/O

PCI_SDIO_XXXX : Sensor GPIO3..0 (General Purpose I/O)

PCI_DIO33_XXXX : User 3.3V GPIO3.3 (General Purpose I/O)

PCI_PWR_DIO_XXXX: Power GPIO GPIO11..0 (General Purpose I/O)

(3) **“Set Dir” button**

Set whether to use each GPIO port as input or output.

If the last bit is “0”, it is an input, and if it is “1”, it is an output.

(4) **“Output” button**

According to the digital I/O selection, the value (“0” or “1”) in the next box is output to the GPIO port.

(5) **“Get Input” button**

According to the digital I/O selection, the value of the GPIO input/output port is read.

3.5 I2C Function

(1) **"Init" button**

Initialize SYS/PWR/ADC/OS I2C communication speed. The initial speed is set to 100 KHz.

(2) **"Write" Button**

It writes the data of the corresponding address in the selected mode among the SYS, PWR, ADC, and OS modes below as much as the data size at the given address.

(3) **"Read" Button**

It reads the data of the corresponding address in the selected mode among the SYS, PWR, ADC, and OS modes below as much as the data size at the given address.

(4) **"Reset" Button**

Initializes the resources of the I2C system of the system (SYS) module.

(5) **"Slave ID" : Slave ID**

"Address " : Slave Register Address

"Len. :" : Address Value

"Data Len. :" : Data Value

"Addr Buf" toggle : Used in SYS mode when selected, address instead of address use a buffer.

"Data :" : data you want to send

The above values are variables used for I2C Read or I2C Write.

(6) **"P/B On" or "P/B Off" button**

On/Off test the power 3.3V on the Power Board.

(7) **"SYS" : System Board**

"PWR" : Power Board

"ADC" : AD Converter Board

"OS" : Open Short Board

3.6 Auto Test Function

- (1) **“RUN” toggle** : Device Open, Init, Clk Set, Sensor power test, etc. are repeatedly performed during the setting period of the Test Period according to the Write Times with the size of the Xres/Yres resolution given below.

“Test Period” : The test cycle can be set in seconds.

“Stop on Err” : Stop error output.

“I2C Test” : Test I2C of SYS, PWR, ADC board.

A related message appears on the log screen below, and in case of failure, a “Fail” message appears.

Count : AutoTest Count, Write error values and Reset Error values are output.

- (2) **“Clear Error Log” Button**

Clear the error log.

3.7 SPI Function

“Get DMA Size” Button : Get the DMA buffer size.

“Set DMA Size” Button : Set the DMA buffer size.

“PCI ddr Reset” Button : Initialize DDR memory.

3.8 OS SPI Function

“**OS SPI Send**” button : Send data to the sensor.

“**Send Bytes**” : The size of bytes to send to the sensor

“**Data0**” : Data0 to send to sensor

“**Data1**” : Data1 to send to sensor

3.9 MISC Function

Several types of states can be selected and used.

“**+5V Power**” : Outputs VIO power.

“**I/O Power**” : Turns on/off the power of external signals used for MIPI.

“**Sensor I2C Off**” : Turns on/off the Sensor I2C operation.

“**Sensor Reset**” : Set the Reset output of the Sensor to High or Low.

“**Sensor Enable**” : Set Enable output of Sensor to High or Low.

“**MCLK Off**” : Turns the master clock output On/Off.

“**Data Check**” : If the frame data is an error, it is counted in the box below.

“View Skip” : Stop the video

“Log Enable” : Enable the log file in the upper right corner.

“View Once” : Show the video once.

(1) **“Clr” button**

Initialize the log message screen below.

3.10 STATUS Function

Status	
OV	overflow
UR	UnRead
SE	SizeError
SI	Size
<input type="checkbox"/>	CRC Check
<input type="checkbox"/>	Frame Check
<input type="checkbox"/>	H/W CRC
<input type="checkbox"/>	Log Enable
	CRC Value
Error	CRC Error
Good	CRC Ok

It shows the number of the following 4 error states that occur during image transmission.

“OV” : **Overflow**

“UR” : **UnRead**

“SE” : **SizeError**

“SI” : **Size**

“CRC Check” : Activate the LVDS Check Sum function.

“Frame Check” : Enable Frame CRC.

“H/W CRC” : Enable hardware CRC.

“Log Enable” : Activate the Log screen.

CRC Value : When CRC Check is performed, the CRC value is displayed.

CRC ERROR : Shows the number of CRC errors when checking CRC

CRC OK : When CRC Check, the number of CRC OKs is displayed.

Appendix

A-1. Board Size

The external dimensions of the board are as follows.

(For detailed dimensions, please ask the person in charge.)

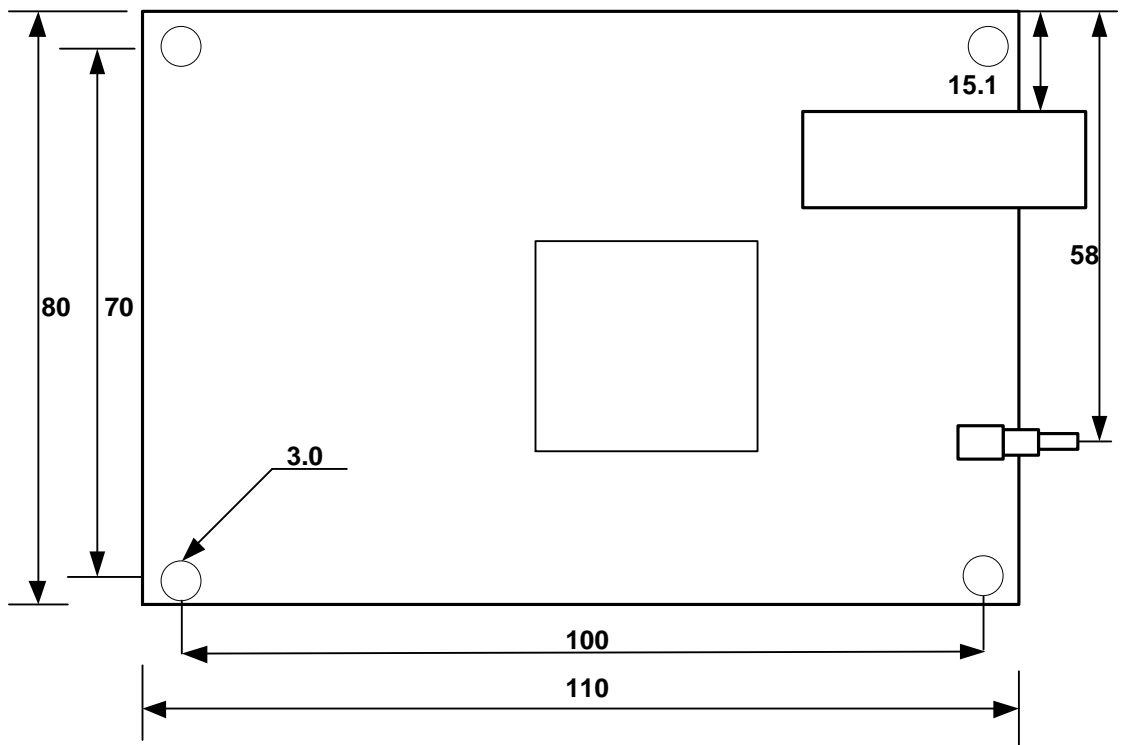

< Top View >

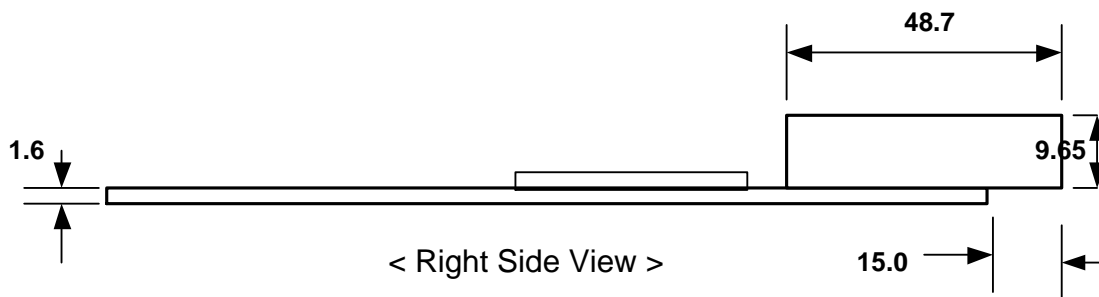

< Right Side View >

A-2. Repair Regulations

Thank you for purchasing a DAQSYSTEM product. Please refer to the following regarding customer service regulated by DAQSYSTEM.

- (1) Read the user manual before using the DAQSYSTEM product and follow the instructions.
- (2) When returning the product to be repaired, please include the symptoms of the failure and send it to the head office.
- (3) The warranty period for all DAQSYSTEM products is one year.
 - . The warranty period is counted from the date the product is shipped from DAQSYSTEM.
 - . Peripherals and third-party products not manufactured by DAQSYSTEM are covered by the manufacturer's warranty.
 - . If you need repair, please contact the Contact Point below.
- (4) Even during the warranty period, repairs will be charged in the following cases.
 - ① Failure or damage caused by use without following the user's manual
 - ② Breakdown or damage caused by customer's negligence during product transportation after purchase
 - ③ Failure or damage due to natural phenomena such as fire, earthquake, flood, lightning, pollution, or power supply exceeding the recommended range
 - ④ Failure or damage caused by inappropriate storage environment (eg, high temperature, high humidity, volatile chemicals, etc.)
 - ⑤ Breakdown or damage due to unfair repair or modification
 - ⑥ Products whose serial number has been changed or deliberately removed
 - ⑦ If DAQSYSTEM determines that it is the customer's fault due to other reasons
- (5) Customer is responsible for shipping costs for returning the repaired product to DAQSYSTEM.
- (6) The manufacturer is not responsible for any problems caused by incorrect use, regardless of our warranty.

MEMO

Contact Point

Web sit : <https://www.daqsystem.com>

Email : postmaster@daqsystem.com

